

# Design of Electronic Devices and Circuits

## Communication Circuits

YOU MAY GET STUDY MATERIAL FROM  
[AMIESTUDYCIRCLE.COM](http://AMIESTUDYCIRCLE.COM)

[INFO@AMIESTUDYCIRCLE.COM](mailto:INFO@AMIESTUDYCIRCLE.COM)

WHATSAPP/CALL: 9412903929

# Communication Circuits

## MODULATION

Modulation is the process by which some character of a high-frequency carrier signal is varied in accordance with the instantaneous value of another signal called modulating or message signal.

The signal containing information to be transmitted is known as modulating or message signal. It is also known as baseband signal. The term "baseband" means the band of frequencies representing the signal supplied by the source of information. Usually, the frequency of the carrier is greater than the modulating signal. The signal resulting from the process of modulation is called modulated signal.

## NEED FOR MODULATION

### For Easy Transmission

By considering that the communication medium is free space, antennas are needed to transmit and receive the signal. The antenna radiates effectively when its height is of the order of wavelength of the signal to be transmitted.

The height of the antenna can be reduced by modulation techniques and it achieves effective radiation. The process of modulation provides frequency translation, i.e. Audio Frequency (AF) signals are translated into Radio Frequency (RF) signals. These RF signals act as carrier signals and AF signals act as message signals. Hence, the height of the antenna required is very much reduced. Here, 1 kHz baseband signal is translated into a high-frequency signal of 1 MHz.

### Narrow Banding

Assume that the baseband signal in a broadcast system is transmitted directly with the frequency range extending from 50 Hz to 10 kHz. If an antenna is designed for 50 Hz, it will be too long for 10 kHz and vice versa. Hence, it is impossible to provide a wideband antenna.

However, if an audio signal is modulated to radio frequency range of 1 MHz then the ratio of lowest to highest frequency will be

$$\frac{10^6 + 50}{10^6 + 10^4} = \frac{1}{1.01} \cong 1$$

Therefore, the same antenna will be suitable for the entire band extending from  $(10^6 + 50)$  Hz to  $(10^6 + 10^4)$  Hz. Thus, modulation converts a wideband signal to narrow band. This is called *narrow banding*.

### Multiplexing

If more than one signal uses a single channel then modulation may be used to translate different signals to different special locations, thus enabling the receiver to select the desired

signal. Application of multiplexing includes data telemetry. FM stereophonic broadcasting and long-distance telephones.

### To Overcome Equipment Limitations

Occasionally, in signal-processing applications, the frequency of the signal to be processed and the frequency range of the processing apparatus does not match. If the equipment is elaborately complex it is necessary to fix some frequency range in the equipment, and translate the frequency range of the signal corresponding to the fixed range of the equipment. The modulation can be used to accomplish this frequency translation.

### Modulation for Frequency Assignment

Modulation allows several radios and TV stations for broadcasting simultaneously at different carrier frequencies and allows different receivers to be tuned to select different stations.

### Modulation to Reduce Noise and Interferences

Even though the effect of noise and interferences cannot be completely eliminated in a communication system, it is possible to minimise the effect, by using certain types of modulation schemes. They require a transmission BW larger than the BW of the message signal.

## MODULATION TYPES

Since it is impractical to propagate information signals over standard transmission media, it is necessary to modulate the source information onto a higher frequency analog signal, a carrier, which carries the information through the system. The information signal modulates the carrier by changing either its amplitude, frequency or phase. Modulation is simply the process of changing one or more properties of the analog carrier in proportion with the information signal. Depending on the types of signals involved in the modulation process, modulation is basically of two types:

- Analog modulation
- Digital modulation

### Analog Modulation

- **Amplitude Modulation (AM)** It is a process in which the information is analog and the amplitude ( $K$ ) of the carrier is varied in accordance with the instantaneous value of the information signal.
- **Frequency Modulation(FM)** It is a process in which the information is analog and the frequency ( $f$ ) of the carrier is varied in accordance with the instantaneous value of the information signal.

- **Phase Modulation (PM)** It is a process in which the information is analog and the phase ( $\theta$ ) of the carrier is varied in accordance with the instantaneous value of the information signal.

## Digital Modulation

- **Amplitude Shift Keying (ASK)** If the information signal is digital and the amplitude ( $V$ ) of the carrier is varied proportional to the information signal, a digitally modulated signal known as Amplitude Shift Keying (ASK) is produced.
- **Frequency Shift Keying (FSK)** If the information signal is digital and the frequency ( $\theta$ ) of the carrier is varied proportional to the information signal, a digitally modulated signal known as Frequency Shift Keying (FSK) is produced.
- **Phase Shift Keying (PSK)** If the information signal is digital and the phase ( $\theta$ ) of the carrier is varied proportional to the information signal, a digitally modulated signal known as Phase Shift Keying (PSK) is produced.

## AMPLITUDE MODULATION

Amplitude modulation is the process of changing the amplitude of the carrier in accordance with the amplitude of the message signal. Frequency and phase of the carrier signal are not altered during the process. It is a low-quality form of modulation and often used for commercial broadcasting of both audio and video signals.

$$V_m(t) = V_m \sin \omega_m t$$

$$V_c(t) = V_c \sin \omega_c t$$

where

$V_m$  is the maximum amplitude of the modulating signal.

$V_c$  is the maximum amplitude of the carrier signal.

$\omega_m$  is the angular frequency of the modulating signal, and

$\omega_c$  is the angular frequency of the carrier signal.

According to the definition,

$$\begin{aligned} V_{AM} &= V_c + V_m \sin \omega_m t \\ &= V_c \left[ 1 + \frac{V_m}{V_c} \sin \omega_m t \right] \\ &= V_c [1 + m_a \sin \omega_m t] \end{aligned}$$

where  $m_a = \frac{V_m}{V_c} =$  modulation index or depth of modulation

## DESIGN OF ELECTRONIC DEVICES & CIRCUITS COMMUNICATION CIRCUITS

### A FOCUSED APPROACH

Modulation index or coefficient is an indicator to describe the amount of amplitude change (modulation) present in an AM waveform (depth of modulation), basically stated in the form of percentage.

$$m_a = \frac{V_m}{V_c} \times 100$$

The instantaneous amplitude of the modulated signal is given by

$$V_{AM}(t) = V_c \sin \omega_c t + \frac{m_a V_c}{2} \cos(\omega_c - \omega_m)t - \frac{m_a V_c}{2} \cos(\omega_c + \omega_m)t$$

### Frequency Spectrum of AM wave

In above, the *first term* of RHS represents the carrier wave. The *second and third terms* are identical, called as Lower Side Band (LSB) and Upper Side Band (USB) respectively.

Following figure shows the frequency spectrum of an AM wave.

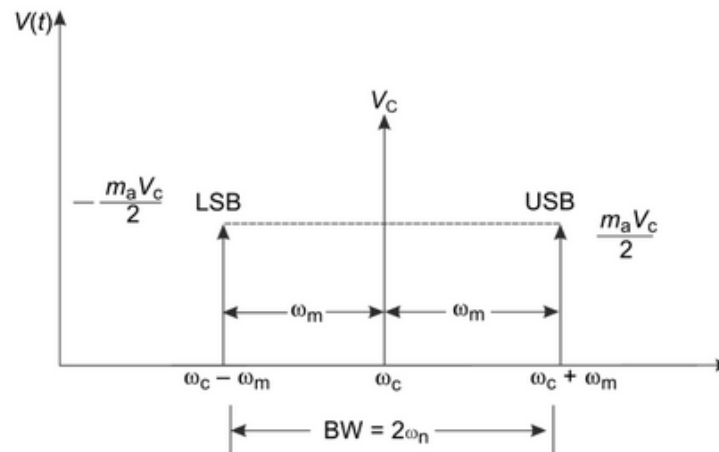

The above figure shows the side-band terms lying on either side of the carrier term which are separated by  $\omega_m$ . The frequency of LSB is  $\omega_c - \omega_m$  and that of USB is  $\omega_c + \omega_m$ . The bandwidth (BW) of AM can be determined by using these side bands. Hence, BW is *twice* the frequency of the modulating signal.

### Power Relation in AM

The modulated wave contains three terms such as carrier wave, Lower Side Band (LSB) and Upper Side Band (USB). Therefore, the modulated wave contains more power than the carrier had before modulation took place. Since the amplitude of side bands depend on the modulation index, it is preserved that the total power in the modulated wave depends on the modulation index.

The total power in the modulated wave will be

$$P_T = P_c + P_{LSB} + P_{USB}$$

$$= \frac{V_c^2}{2R} + \frac{m_a V_c^2}{8R} + \frac{m_a V_c^2}{8R}$$

where  $V_c$  = Maximum amplitude of carrier wave

After simplification

$$P_T = P_C \left[ 1 + \frac{m_a^2}{2} \right]$$

If  $m_a = 1 = 100\%$

Then  $\frac{P_T}{P_C} = 1.5$

### Example

*The total power content of an AM signal is 1000 W. Determine the power being transmitted at the carrier frequency and at each of the side bands when the % modulation is 100%.*

### Solution

The total power consists of the power at the carrier frequency, that at the upper side band and that at the lower side band. Since the % modulation is 100%,  $m_a = 1$ .

$$\begin{aligned} P_T &= P_C + P_{LSB} + P_{USB} \\ &= P_C + \frac{m_a^2 P_C}{4} + \frac{m_a^2 P_C}{4} \\ &= P_C + \frac{m_a^2 P_C}{2} \end{aligned}$$

Now  $1000 = P_C + \frac{(1.0)^2 P_C}{2}$

$\therefore P_C = 666.67 \text{ W}$

This leaves  $1000 - 666.67 = 333.33 \text{ W}$  to be shared equally between upper and lower side bands.

$$P_{USB} + P_{LSB} = 333.33 \text{ W}$$

In AM,  $P_{USB} = P_{LSB}$

$\therefore 2P_{LSB} = 333.33$

$\therefore P_{USB} = P_{LSB} = \frac{333.33}{2} = 166.66 \text{ W}$

Determine the power content of the carrier and each of the side hands for an AM signal having a percent modulation of 80% and a total power of 2500 W.

Answer: 303.5 W

### Problem

Find the percent modulation of an AM wave whose total power content is 2500 W and whose side hands each contain 400 W.

Answer: 97%

### Example (AMIE Winter 2016, 6 marks)

The percent modulation of an AM wave changes from 40% to 60%. Originally, the power content at the carrier frequency was 900 W. Determine the power content at the carrier frequency and within each of the side bands after the percent modulation has risen to 60%.

### Solution

In standard AM transmission, carrier power remains the same, regardless of percent modulation.

$$P_{C60} = P_{C40} = 900W$$

Power in side bands for 60% modulation is,

$$\begin{aligned} P_{LSB} = P_{USB} &= \frac{m_a^2 P_c}{4} \\ &= \frac{(0.60)^2 (900)}{4} 81.0 \end{aligned}$$

$$\therefore P_{LSB} = P_{USB} = 81.0w$$

### Percentage Efficiency

It can be defined as the ratio of power in side bands to total power because side bands only contain the useful information.

It is given by

$$\begin{aligned} \% \eta &= \frac{\text{total power in side bands}}{\text{total power}} \times 100 \\ &= \frac{P_{LSB} + P_{USB}}{P_T} \times 100 \end{aligned}$$

Putting values, we finally get

$$\% \eta = \frac{m_a^2}{2 + m_a^2} \times 100$$

### Problem

Determine percentage efficiency and percentage of the total power carried by the side bands of the AM wave when  $m_a = 0.5$  and  $m_a = 0.3$ .

Answer: 11.11%; 43%

### Generation of AM waves

The methods for generation of AM waves are classified into two major types:

- Nonlinear modulators
- Linear modulators

#### Nonlinear AM modulators

The relation between the amplitude of the modulating signal and the resulting depth of modulation is nonlinear in this type of modulators. In general, any device operated in nonlinear region of its output characteristic is capable of producing AM waves when the carrier and the modulating signals are fed at the input. The devices making use of nonlinear V-I characteristics are diodes, triode tubes. Bipolar Junction Transistors (BJTs) and Field Effect Transistors (FETs), which are also called **square-law modulators**. They are suitable for use at low operating voltages.

In such a nonlinear modulator, the output current flowing through the load is given by the power series

$$i = a_0 + a_1 e_1 + a_2 e_1^2 + \dots$$

where  $a_0 + a_1, a_2, \dots$  are constants and  $e_1$  is the input voltage to the device.

Following figure shows a basic non linear modulator.

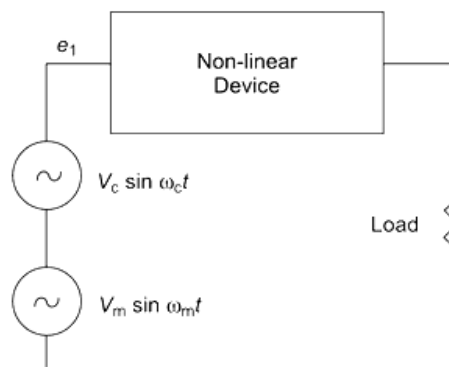

$$e_1 = V_c \sin \omega_c t + V_m \sin \omega_m t$$

$$\therefore i = a_0 + a_1(V_c \sin \omega_c t + V_m \sin \omega_m t) + a_2(V_c \sin \omega_c t + V_m \sin \omega_m t)^2 + \dots$$



**DESIGN OF ELECTRONIC DEVICES & CIRCUITS**  
**COMMUNICATION CIRCUITS**
**A FOCUSED APPROACH**

The last term of this gives the upper and lower side bands while the second term gives the carrier. If the load is a resonant circuit, side bands and carrier may be selected giving the AM output.  $a_1$  is considerably larger than  $a_2$ , the depth of modulation that is available without distortion is low. Also note that the circuit efficiency is quite low because a sufficient number of components are filtered out from the plate current. Thus, this type of circuit is essentially a low-level circuit. A common triode-tube circuit using the square-law modulation technique is shown in following figure.

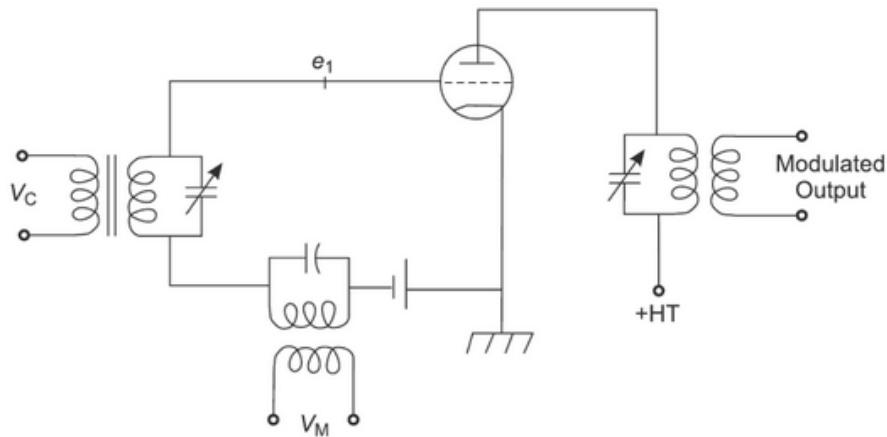

Following figure shows square-law modulator using diode.

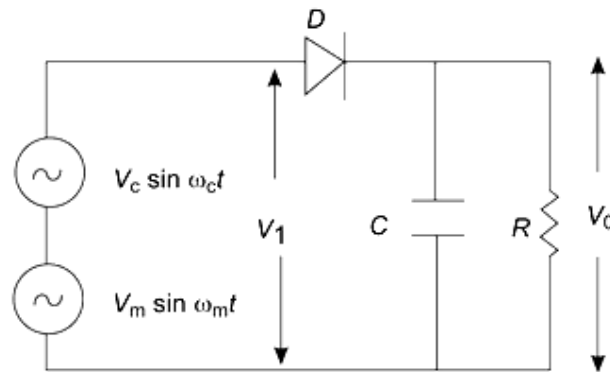

The operation of the diode square-law modulator is as follows. Due to the nonlinearity of transfer characteristics of the diode, the magnitude of the carrier component is greater during the positive half cycle of the modulating voltage and lesser in magnitude during the negative half cycle of the modulating signal.

The diode modulator does not provide amplification and a single diode is unable to balance out the undesired frequency completely. These limitations can be eliminated by using amplifying devices like transistor and FET in a balanced mode. Following figure shows the low-level modulator using a transistor.

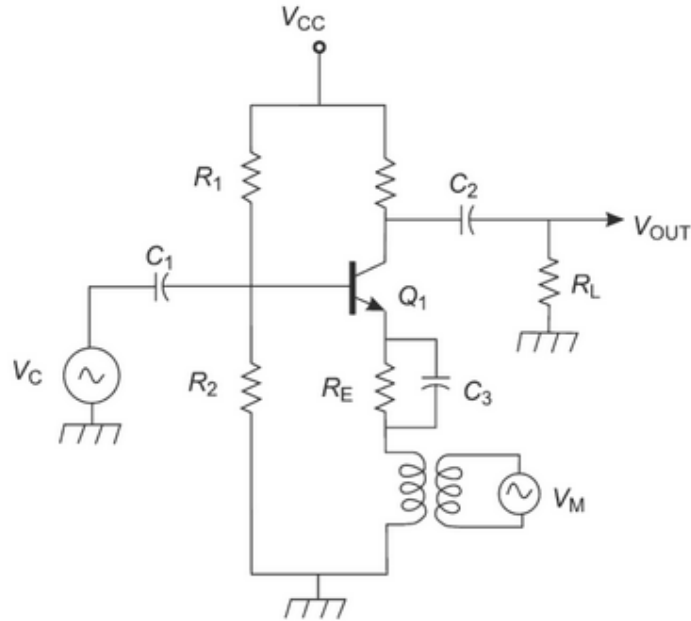

### Advantages of a Low-level Modulator

- Less modulating signal power is required to achieve high percentage of modulation
- The advantage of using a linear RF amplifier is that the smaller early stages can be modulated, which only requires a small audio amplifier to drive the modulator.

### Disadvantages of a Low-level Modulator

The great disadvantage of this system is that the amplifier chain is less efficient, because it has to be linear to preserve the modulation.

### AM Demodulation

The reverse process of amplitude modulation is called AM demodulation from which the original modulating signal is recovered from a modulated wave. AM demodulators, or detectors, are circuits that accept amplitude-modulated signals and recover the original modulating signal or message signal.

An ideal demodulator should produce at its output a demodulated signal that resembles the original modulating signal in all respects. If there is any deviation from the wave shape of the modulating signal, it is termed distortion.

### Synchronous or Coherent Detector

The synchronous detector uses carrier synchronisation for retrieving the message signal. These detectors are mainly used for detecting DSB SC or SSB SC signals because of their empirical nature. Figure 3.6 shows the block diagram of a synchronous detector.

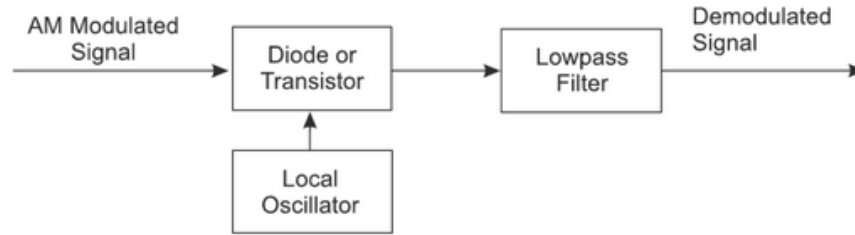

The incoming AM modulated signal is first multiplied with a locally generated carrier signal and then entered through a lowpass filter. The filter bandwidth is same as the message bandwidth or sometimes larger. It is assumed that the local oscillator is exactly synchronised with the carrier in both phase and velocity, hence the name *synchronous detector*.

The final recovered information signal is given by

$$V_0 = \frac{m_a V_c V}{4} \sin \omega_m t$$

Thus, the synchronous detector is capable of demodulating DSB-SC and SSB SC AM. However, the synchronous detector is effective only when the locally generated signal is properly synchronised with the modulating signal. Any shift in phase or frequency of the carrier from the local oscillator results in phase or delay distortion.

A practical synchronous detector is shown in following figure, in which a centre-tapped transformer provides the two equal but inverted signals. The carrier signal is applied to the centre tap.

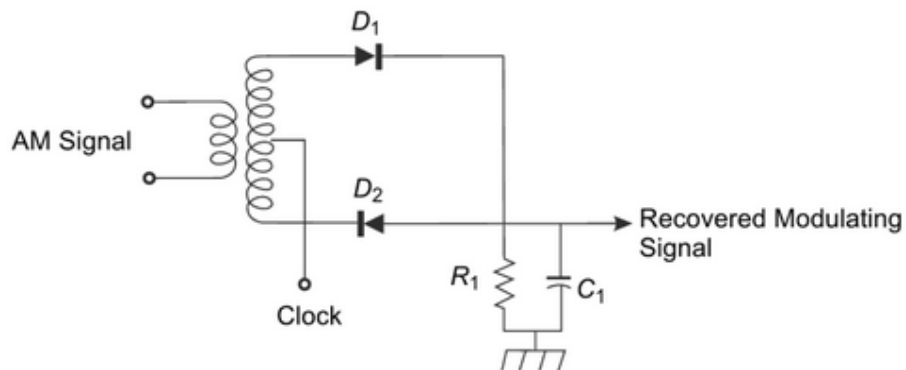

When the clock is positive,  $D_1$  is forward biased and it acts as a short circuit and connects the AM signal to the load resistor. As a result, positive half cycles appear across the load. When clock is negative,  $D_2$  is forward biased. During this time, the negative cycles of the AM signal are occurring, which makes the lower output of the secondary winding positive. With  $D_2$  conducting, the positive half cycles are passed to the load and the circuit performs full-wave rectification. As a result, the capacitor across the load filters out the carrier, leaving the original modulating signal across the load.

### Square Law Detectors

**DESIGN OF ELECTRONIC DEVICES & CIRCUITS**  
**COMMUNICATION CIRCUITS**
**A FOCUSED APPROACH**

The square law detecting modulated signal of small magnitude (i.e. below 1 volt) so that the operating region may be restricted to the non-linear portion of the V-I characteristics of the device. Figure shows the circuit of a square-law detector. It may be observed that the circuit is very similar to the square-law modulator. The only difference lies in the filter circuit. In a square law modulator, the filter used is a band-pass filter whereas in a square law detector, a low-pass filter is used.

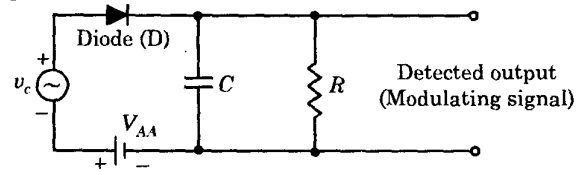

In the circuit, the dc supply voltage  $V_{AA}$  is used to get the fixed operating point in the non-linear portion of the diode V-I characteristic. Since, the operation is limited to the non-linear region of the diode characteristics, the lower half-portion of the modulated waveform is compressed. This produces envelope applied distortion. Due to this, the average value of the diode-current is no longer constant, rather it varies with time as shown in figure below.

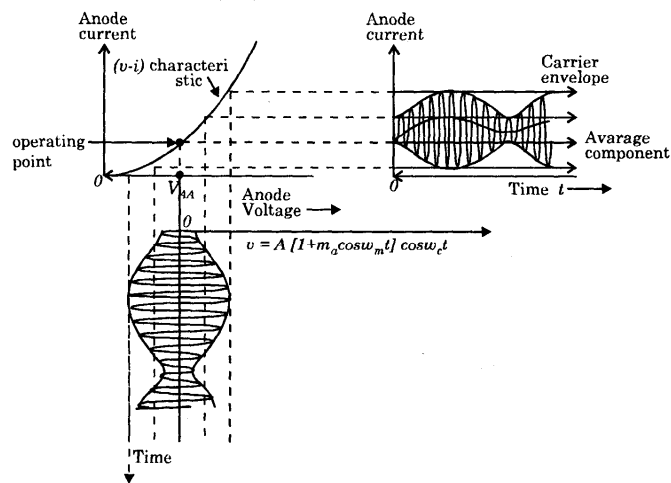

This distorted output diode current is expressed by the non-linear v-i relationship (i.e. square law) as

$$i = av + bv^2 \quad (i)$$

Here,  $v$  is the input modulated voltage.

We know that AM wave is expressed as

$$v = A(1 + m_a \cos \omega_m t) \cos \omega_c t \quad (ii)$$

Substituting, the value of  $v$  in equation (i), we get

$$i = a[A(1 + m_a \cos \omega_m t) \cos \omega_c t] + b[A(1 + m_a \cos \omega_m t) \cos \omega_c t]^2 \quad (iii)$$

Now, if above expression is expanded, then we may observe the presence of terms of frequencies like  $2\omega_c$ ,  $2(\omega_c \pm \omega_m)$ ,  $\omega_m$  and  $2\omega_m$  besides the input frequency terms.

Hence, this diode current  $i$  containing all these frequency terms is passed through a low-pass filter which allows to pass the frequencies below or upto modulating frequency  $w_m$  and rejects the other higher frequency components. Therefore, the modulating or baseband signal with frequency  $w_m$  is recovered from the input modulated signal

**Linear Diode or Envelope Detector**

It is a known fact that a diode operating in a linear region of its V-I characteristics can extract the envelope of an AM wave. This type of detector is known as **envelope detector** or a **linear detector**. Envelope detector is most popular in commercial receiver circuits since it is very simple and is not expensive, also at the same-time it gives satisfactory performance for the reception of broadcast programmes. Given figure shows the circuit diagram of a linear diode detector or envelope detector.

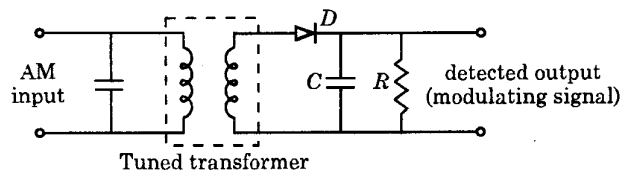

In the input portion of the circuit, the tuned transformer provides perfect tuning at the desired carrier frequency. R-C network is the time constant network. If the magnitude of the modulated signal at the input of the detector is 1 volt or more, the operation takes place in the linear portion of the V-I characteristics of diode. Given figure shows the idealized linear characteristics of the diode along with the input voltage and output current waveforms.

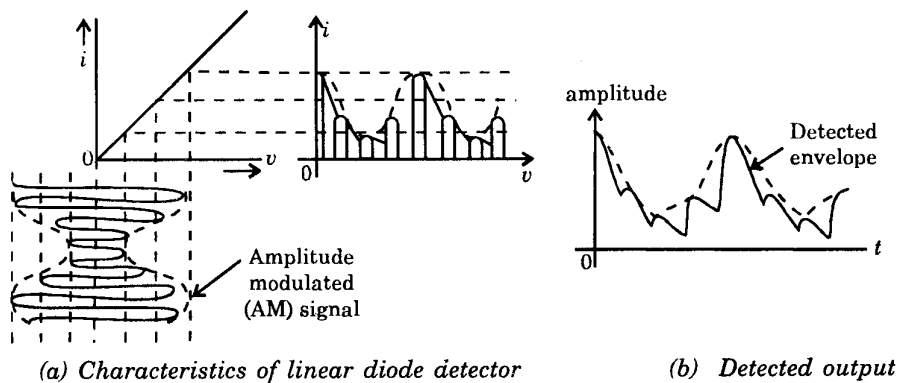

**Operating Principle.** First of all, let us assume that the capacitor is absent in the circuit. In this case, the detector circuit will work as a half-wave rectifier. Therefore, the output waveform would be a half-rectified modulated signal as shown in figure (b). Now let us consider that the capacitor is introduced in the circuit. For the positive half-cycle, the diode conducts and the capacitor is charged to the peak value of the carrier voltage. However, for a negative half-cycle, the diode is reverse-biased and does not conduct. This means that the input carrier voltage is disconnected from the R-C circuit. Therefore, the capacitor starts discharging through the resistance R with a time-constant  $\tau = RC$ . If the time-constant  $\tau = RC$  is suitably chosen, the voltage across the capacitor C will not fall appreciably during the

small period of negative half-cycle, and by that time the next positive cycle appears. This positive cycle again charges the capacitor  $C$  to the peak value of the carrier voltage and thus this process repeats again and again.

Hence, the output voltage across the capacitor  $C$  is a spiky modulating or baseband signal.

### Drawbacks of AM

In conventional AM double side-band system, the carrier signal does not carry information: the information is contained in the side bands.

Due to the nature of this system, the drawbacks are as follows:

- Carrier power constitutes two-thirds or more of the total transmitted power.
- Both side bands contain the same information. Transmitting both side bands is redundant and thus causes it to utilise twice as much bandwidth as needed with single side-band system.
- Conventional AM is both power- and bandwidth-inefficient.

### DOUBLE-SIDE-BAND SUPPRESSED-CARRIER AMPLITUDE MODULATION (DSB-SC-AM)

The major considerable parameters of a communication system are transmitting power and bandwidth. Hence, it is very much necessary to save the power and bandwidth in a communication system.

In AM with carrier, from the calculation of efficiency, it is found that *only* 33.3% of energy is used and the remaining power is *wasted* by the carrier transmission along with the side bands.

In order to save the power in amplitude modulation, the carrier is suppressed, because it does not contain any useful information. This scheme is called the Double-Side-Band Suppressed-Carrier Amplitude Modulation (DSB-SC AM).

It contains *only* LSB and USB terms, resulting in a transmission bandwidth that is twice the bandwidth of the message signal.

Let the modulating signal be

$$V_m(t) = V_m \sin \omega_m t$$

and carrier signal be

$$V_c(t) = V_c \sin \omega_c t$$

When multiplying both the carrier and modulating signals, the product which is obtained is the DSB-SC AM signal.

$$\begin{aligned} V(t)_{DSB-SC} &= V_m \sin \omega_m t + V_c \sin \omega_c t \\ &= V_m V_c \sin \omega_m t \sin \omega_c t \end{aligned}$$

$$= \frac{V_m V_c}{2} [\cos(\omega_c - \omega_m)t - \cos(\omega_c + \omega_m)t] \quad (1)$$

We know that

$$V(t)_{AM} = V_c \sin \omega_c t + \frac{m_a V_c}{2} \cos(\omega_c - \omega_m)t - \frac{m_a V_c}{2} \cos(\omega_c + \omega_m)t \quad (2)$$

By comparing Equation (1) and Equation (2), the carrier term  $V_c \sin \omega t$  is missing and only two side bands are present in Equation (1). Hence, it is said to be **DSB-SC AM**.

Following figure shows the frequency spectrum of DSB-SC AM, from which it is clear that the carrier term  $\omega_c$  is suppressed. It contains only two side-band terms having the frequency of  $(\omega_c - \omega_m)$  and  $(\omega_c + \omega_m)$ . Hence, this scheme is called DSB-SC AM.

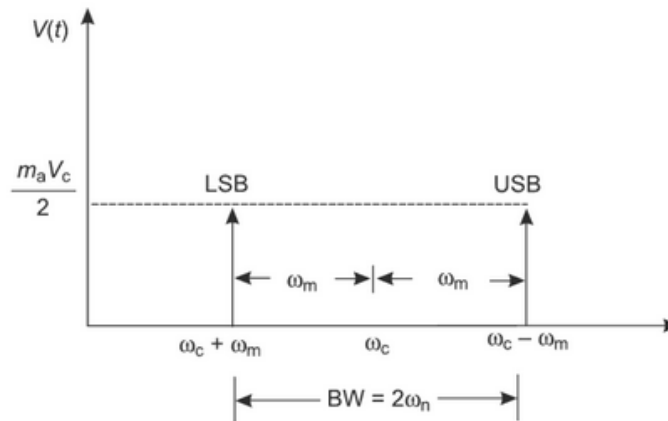

Following figure shows the graphical representation of DSB-SC AM. It exhibits the phase reversal at zero crossing.

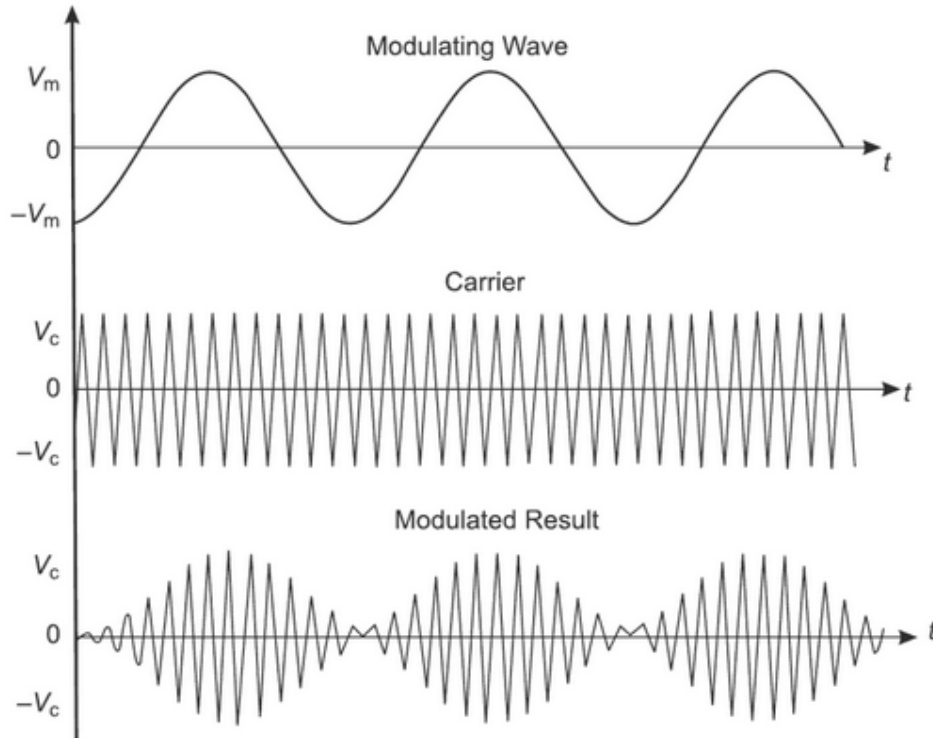

**Graphical representation of DSB-SC AM**

### Generation of DSB-SC signal

The expression for DSB-SC signal is given as

$$s(t) = x(t) \cos \omega_c t$$

Where,  $x(t)$  = Baseband signal

$\cos \omega_c t$  = carrier signal

From this expression, we see that a DSB-SC signal is basically the product of the modulating or base-band signal and the carrier signal. A circuit to achieve the generation of a DSB-SC signal is called a product modulator. In this section, we shall discuss two types of product modulator, namely the Balanced Modulator and the Ring Modulator.

#### The Balanced Modulator

We know that a non-linear resistance or a non-linear device may be used to produce Amplitude Modulation, i.e., one carrier and two sidebands. However, as diodes, transistors, etc. are connected in a balanced mode so as to suppress the carriers of each other, then only sidebands are left, i.e., a DSB-SC signal is generated.

Therefore, a balanced modulator may be defined as a circuit in which two non-linear devices are connected in a balanced mode to produce a DSB-SC signal.



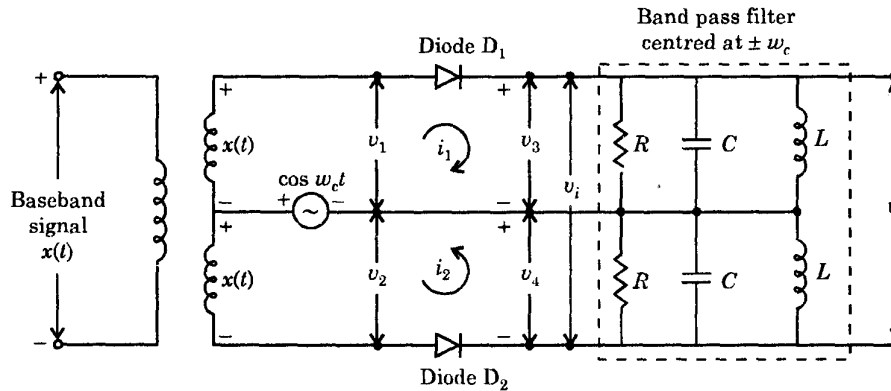

Given figure shows a balanced modulator circuit using two diodes. A modulating signal  $x(t)$  is applied to the two diodes through a centre-tapped transformer with the carrier signal  $\cos \omega_c t$ .

A non-linear  $v$ - $i$  relationship is given as

$$i = av + bv^2$$

Here, we have neglected the higher power terms.

In above expression,  $v$  is the input voltage applied across a non-linear device and  $i$  is the current through the non-linear device.

Elaborating  $v_i = 2R [ax(t) + 2bx(t) \cos \omega_c t]$

This voltage  $v_i$  is the input to the bandpass filter centered around  $\pm \omega_c$ .

A bandpass filter is that type of filter which allows to pass a band of frequencies. Here, since the bandpass filter is centred around  $\pm \omega_c$ , it will pass a narrow band of frequencies centred at  $\pm \omega_c$  with a small bandwidth of  $2\omega_m$  to preserve the sidebands.

Therefore, the output of BPF centred around  $\pm \omega_c$  is given by

$$v_0 = 4a R x(t) \cos \omega_c t = K x(t) \cos \omega_c t$$

which is the expression for a DSB-SC signal

### Ring Modulator

Ring modulator is another product modulator, which is used to generate DSB-SC signal. Given (a) shows the circuit diagram of a ring modulator. In a ring modulator circuit, four diodes are connected in the form of a ring in which all four diodes point in the same manner. All the four diodes in ring are controlled by a square wave carrier signal  $c(t)$  of frequency  $f_c$  applied through a centre-tapped transformer.

In case, when diodes are ideal and transformer are perfectly balanced, the two outer diodes are switched on if the carrier signal is positive whereas the two inner diodes are switched off and thus presenting very high impedance as shown in figure (b). Under this condition, the modulator multiplies the modulating signal  $x(t)$  by +1.

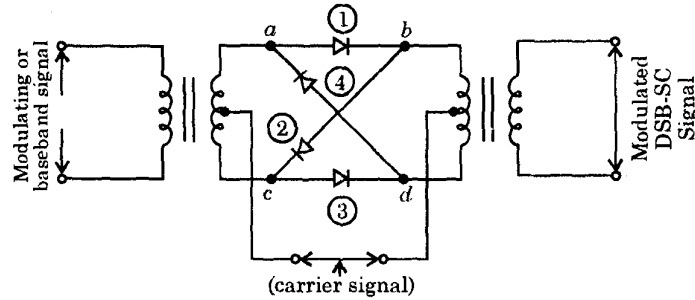

(a)

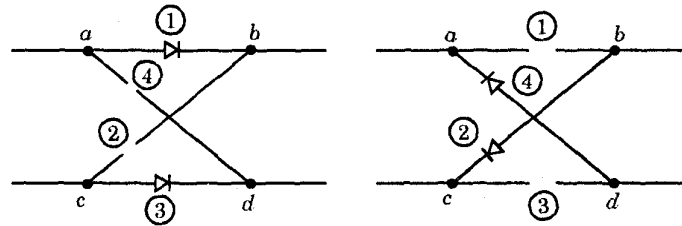

(b)

(c)

Now, in case when carrier signal is negative, the situation becomes reversed as shown in figure(c). In this case, the modulator multiplies the modulating signal by -1.

Hence, the ring modulator is a product modulator for a square wave carrier and modulating signal.

The output from ring modulator does not have any component at carrier frequency. Hence, the modulated output does not have any component at carrier frequency. Hence, the modulated output contains only product terms.

A ring modulator is also known as a double-balanced modulator since it is balanced with respect to the baseband signal as well as the square wave carrier signal.

The frequency spectrum of the ring modulator output contains sidebands around each of the odd harmonics of the square wave carrier signal as illustrated in figure. We have assumed that the modulating or baseband signal is bandlimited to  $-f_m \leq f \leq f_m$ . The desired sideband around the carrier frequency  $f_c$  may be selected by using a bandpass filter (BPF) having center frequency  $w_c$  and bandwidth  $2f_m$ .

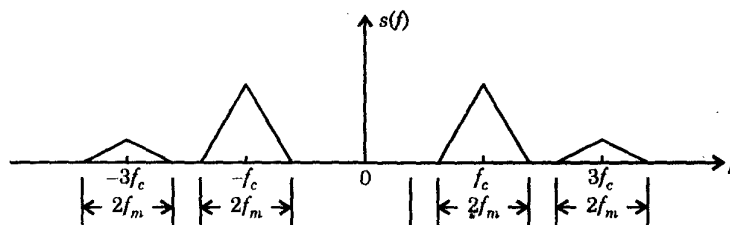

From figure, it may be observed that to avoid overlapping of sidebands we must have  $f_c > f_m$ .

## Demodulation of DSB-SC Signals

The DSB-SC signal may be demodulated by following two methods :

- Synchronous detection method
- Using envelope detector after carrier re-insertion.

### Synchronous Detection Method

We know that the DSB-SC system is used at the transmitter end to shift the modulating signal (having maximum frequency  $w_m$ ) to a higher carrier frequency  $\pm\omega_c$ . Now, this modulated (DSB-SC) signal is transmitted from the transmitter and it reaches the receiver through a transmission medium. At the receiver end, the original modulating signal  $x(t)$  is recovered from the modulated (DSB-SC) signal. This can be achieved by simply retranslating the baseband or modulating signal from a higher spectrum, centered at  $\pm\omega_c$ , to the original spectrum. This process of retranslation is called demodulation or detection. Hence, the original or baseband signal is recovered from the modulated signal by the detection process.

A method of DSB-SC detection is known as synchronous detection. Figure below shows the block diagram of synchronous detection method.

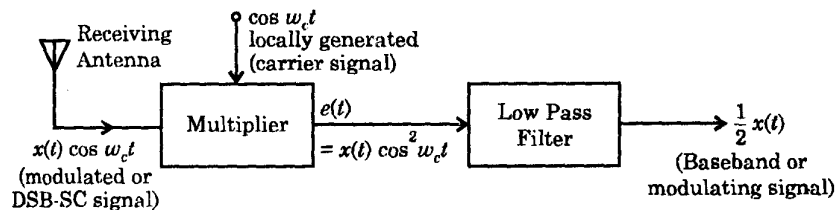

In synchronous detection method, the received modulated or DSB-SC signal is first multiplied with a locally generated carrier  $\cos\omega_c t$  and then passed through a low pass filter (LPF). At the output of a low pass filter (LPF), the original modulating signal is recovered.

Mathematically

$$e(t) = \underbrace{x(t) \cos \omega_c t}_{\text{DSB-SC signal}} \cdot \underbrace{\cos \omega_c t}_{\text{locally generated carrier signal}}$$

or 
$$e(t) = x(t) \cos^2 \omega_c t = \frac{1}{2} x(t) [2 \cos 2\omega_c t]$$

or 
$$e(t) = \frac{1}{2} x(t) [1 + \cos 2\omega_c t] = \frac{1}{2} x(t) + \frac{1}{2} x(t) \cos 2\omega_c t$$

Now, it may be observed that when multiplied signal  $e(t)$  is passed through a low pass filter (LPF), then the term  $\frac{1}{2} x(t) \cos 2\omega_c t$ , centered at  $\pm 2\omega_c$  is suppressed by low pass filter and

thus at the output of low pass filter, the original modulating signal  $\frac{1}{2} x(t)$  is obtained.

### Envelope Detection after Suitable Carrier Re-insertion

The other possible method of demodulating DSB-SC signal is by inserting a carrier generated at the receiver end with the help of a local oscillator. However, the phase and the frequency of the re-inserted carrier must be properly synchronized with those at the transmitter end in order to avoid distortion. We know that if we insert a sufficient carrier of same frequency and phase to DSB-SC signal, it converts DSB-SC signal into a conventional AM wave. Now, this AM wave is demodulated by an envelope detector.

### Synchronization In DSB-SC System

#### Costa's Receiver

This system used for synchronous detection of DSB-SC signal has been shown in given figure.

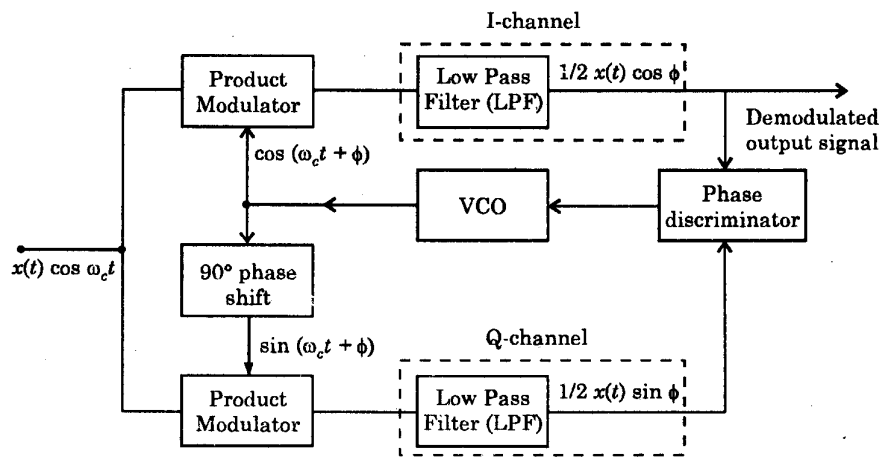

This system has two synchronous detectors - one detector is fed with a locally generated carrier signal which is in phase with the transmitted carrier signal. This detector circuit is called inphase coherent detector or I-channel. The other synchronous detector employs a local carrier which is in phase quadrature with the transmitted carrier signal and is called Quadrature phase coherent detector. On combining, the two detectors constitute a negative feedback system which synchronizes the local carrier signal with the transmitter carrier signal.

**Operating Principle.** To start with, let us assume that the local carrier signal is synchronized with the transmitted carrier signal and  $\phi = 0$ . As shown in figure the output of the I-channel is the desired modulating signal (since  $\cos\phi = 1$ ), but the output of the Q-channel is zero (since  $\sin\phi = 0$ ) because of the quadrature null effect. Now, assuming that the local oscillator frequency drifts slightly i.e.,  $\phi$  is a very small non-zero quantity, I-channel output will be almost unchanged, but Q-channel output now is not a zero, rather some signal would appear at its output and is proportional to  $\sin\phi$ . Thus, the output of the Q-channel,

- is proportional to  $\phi$  (since  $\sin\phi = \phi$  for small  $\phi$ )

- would have a polarity same as the I-channel for one direction of phase shift in local oscillator, whereas, the polarity would be opposite to I-channel for the other direction of phase shift.

The phase discriminator provides a dc control signal which may be used to correct local oscillator phase error. The local oscillator is a voltage controlled oscillator (VCO). Its frequency may be adjusted by an error control d.c. signal.

### **Advantage of DSB-SC AM**

- Efficient in terms of power usage
- Low power consumption
- 100% modulation efficiency
- Large bandwidth

### **Disadvantage of DSB-SC AM**

- Product detector required for demodulation of DSB signal which is quite expensive
- Complex detection
- Signal rarely used because the signal is difficult to recover at the receiver

### **Applications of DSB-SC AM**

- Used in analog TV systems to transmit the colour information
- For transmitting stereo information in FM sound broadcast at VHF

## **COMPARISON OF VARIOUS AM SYSTEMS**

The relative merits and demerits of various forms of AM can be summarized below:

- The demodulation or detection of AM signal is simpler than DSB-SC and SSB systems. The conventional AM can be demodulated by rectifier or envelope detector. Detection of DSB-SC and SSB is rather difficult and expensive also. Furthermore, it is quite easier to generate conventional AM signals at high power levels as compared to DSB-SC and SSB signals. For this reason, conventional AM systems are used for broadcasting purpose.
- The advantage of DSB-SC and SSB systems over conventional AM system is that the former requires lesser power to transmit the same information. For sinusoidal modulation the carrier consumes about  $\frac{2}{3}$  of the total power for 100% modulation in conventional AM. However, only  $\frac{1}{3}$  of the total power is carried by the side-bands which carry the information. This makes AM transmitters less efficient. On the other hand, the receivers of DSB-SC and SSB systems, though efficient, are much more complex and expensive too. Due to this reason, DSB-SC and SSB systems only find applications in point-to-point communication. In point to point communication only a few receivers and one transmitter are needed. In public broadcast system one

transmitter caters to millions of receivers. It is obviously needed to be the simpler and cheaper.

- SSB scheme needs only one-half of the bandwidth required in DSB-SC system and less than that required in VSB also. Thus, we can say that SSB modulation scheme is the most-efficient scheme among DSB-SC and VSB schemes. SSB modulation scheme is used for long distance transmission of voice signals because it allows longer spacing between repeaters.
- Vestigial side-band (VSB) modulation requires a transmission band width intermediate between requires in SSB and DSB-SC systems. The saving in bandwidth is significant when the modulating signal has a very large bandwidth (for example TV signals)
- Conventional AM, DSB-SC, SSB and VSB modulation schemes are all examples of linear modulation scheme. But conventional AM fails to meet the definition of linear modulation in the strict sense. For example, if  $s_1(t)$  is the AM wave generated by the message signal  $m_1(t)$  and  $s_2(t)$  is the AM wave generated by the message signal  $m_2(t)$ , then the AM wave generated by  $[m_1(t) + m_2(t)]$  is not equal to  $[s_1(t) + s_2(t)]$ .

## AM SUPERHETERODYNE RECEIVERS

Superheterodyne principle is the process of operation on modulated radio waves to obtain similarly modulated waves of different frequencies. This process includes the use of an input signal with the local oscillator signal which determines the change of frequency.

A superheterodyne receiver may be defined as one in which one or more changes of frequency take place before the AF signal is extracted from the modulated wave. A receiver in which the change of frequency takes place twice before detection is usually called a double superheterodyne receiver.

In superheterodyne receivers, the modulated signal of the carrier frequency ( $f_m$ ) is fed to a circuit called mixer to which is also fed the voltage at frequency ( $f_0$ ) generated by a local oscillator. As a result, the output of the mixer stage is a voltage of frequency ( $f_{IF}$ ), which is the difference of the signal frequency  $f_m$  and the local oscillator frequency  $f_0$ . This difference frequency is called **Intermediate Frequency (IF)**. The signal frequency and the local oscillator frequency can be varied by using ganged tuned capacitors in these stages. This results in a mixer output that has a constant frequency irrespective of the frequency to which the receiver may be tuned. Thus, IF is fixed for a receiver. It should be noted that the IF signal is exactly similar to the modulated signal and the only difference is in their carrier frequencies.

The IF amplifiers, being tuned voltage amplifiers, use transformers in the input and output circuits. Each of these transformers consists of a pair of mutually coupled tuned circuits. With these fixed-frequency tuned circuits as plate load, the IF amplifiers provide most of the gain and selectivity to the receiver. As the gain and selectivity of IF amplifiers remain constant at

all incoming signal frequencies, the sensitivity and selectivity of the receiver is fairly uniform over the entire frequency range.

The block diagram of a superheterodyne receiver is shown in following figure.

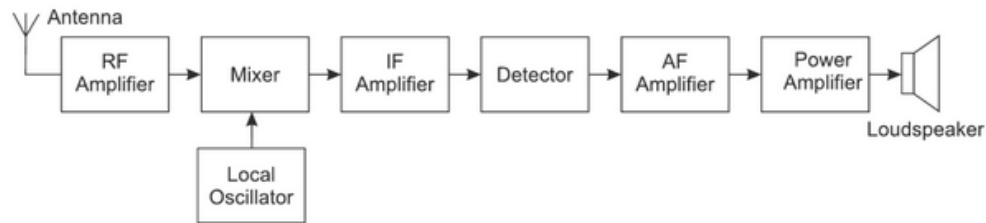

Basically, the receiver consists of an RF section, a mixer and a local oscillator, one IF section, a detector and a power amplifier.

### **RF Amplifier**

The incoming AM signal is picked up by the receiving antenna first and is passed to the RF amplifier. The RF amplifier is a tuned voltage amplifier and couples the antenna to the mixer. It selects the desired signals from the antenna and amplifies the signals to the requisite level.

### **Local Oscillator**

All local oscillators are LC oscillators and use a single tuned circuit to determine the frequency of oscillation.

### **Frequency Changers**

The combination of a mixer and local oscillator constitute the frequency changer. Both of them provide 'heterodyne' function, where the incoming signal is converted to a predetermined fixed frequency called the intermediate frequency. This intermediate frequency is lower than the incoming carrier frequency.

### **IF Section**

Intermediate Frequency (IF) amplifiers are tuned voltage amplifiers that are operated in Class A with a fixed resonant load. The IF section has the bandwidth corresponding to the required signal that the receiver is intended to handle. This section provides most of the amplification and selectivity of the receiver.

### **Demodulator or Detector**

The output of the IF amplifier section is fed to a demodulator which recovers the baseband or message signal. Diode detector is most common choice in radio receivers. If coherent detection is used, then a coherent signal source must be provided in the receiver. The detector also supplies dc bias voltage to RF and IF stages in the form of an AGC circuit. Finally, the recovered signal is power amplified en-route to the loudspeaker.

A phase locked loop is basically a closed loop system designed to lock the output frequency and phase to the frequency and phase of an input signal. It is commonly abbreviated as PLL. The PLL was first introduced in its discrete form in early 1930s. The high cost of realizing PLL in discrete form limited its use earlier. Now with the advanced IC technology, PLLs are available as inexpensive monolithic ICs. They are used in applications such as frequency synthesis, frequency modulation/demodulation, AM detection, tracking filters, FSK demodulator, tone detector etc.

### Basic PLL Operation

Following figure shows the block diagram of PLL. It consists of Phase detector, Low pass filter, Error amplifier, Voltage Controlled Oscillator (VCO).

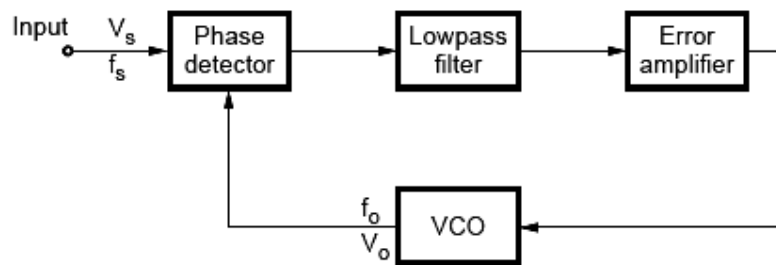

The phase detector compares the input frequency  $f_s$  with the feedback frequency  $f_o$  and generates an output signal which is a function of the *difference* between the phases of the two input signals. The output signal of the phase detector is a dc voltage. The output of phase detector is applied to low pass filter to remove high frequency noise from the dc voltage. The output of low pass filter without high frequency noise is often referred to as error voltage or control voltage for VCO. When control voltage is zero, VCO is in free-running mode and its output frequency is called as center frequency  $f_o$ .

The non-zero control voltage results in a shift in the VCO frequency from its free-running frequency,  $f_o$  to a frequency  $f$ , given by  $f = f_o + K_v V_c$ , where  $K_v$  is the voltage to frequency transfer coefficient of the VCO. The error or control voltage applied as an input to the VCO, forces the VCO to change its output frequency in the direction that reduces the difference between the input frequency and the output frequency of VCO.

This action, commonly known as capturing, continues till the output frequency of VCO is same as the input signal frequency. Once the two frequencies are same, the circuit is said to be locked. In locked condition, phase detector generates a constant dc level which is required to shift the output frequency of VCO from centre frequency to the input frequency. Once locked, PLL tracks the frequency changes of the input signal. Thus, a PLL goes through three states : Free running, capture and phase lock.

### Important Definitions Related to PLL

Some important definitions related to PLL are as follows:



- **Lock Range** When PLL is in lock, it can track frequency changes in the incoming signal. The range of frequencies over which the PLL can maintain lock with the incoming signal is called the lock range or tracking range of the PLL. It is usually expressed as a percentage of  $f_o$ , the VCO frequency.
- **Capture Range** The range of frequencies over which the PLL can acquire lock with an input signal is called the capture range. It is also expressed as a percentage of  $f_o$ .
- **Pull-In Time** The capture of an input signal does not take place as soon as the signal is applied, but it takes finite time. The total time taken by the PLL to establish a lock is called pull-in time. This depends on the initial phase and frequency difference between the two signals as well as on the overall loop gain and the bandwidth of the low pass filter.

### Derivation of LOCK Range

The following figure shows the block diagram to determine lock-range.

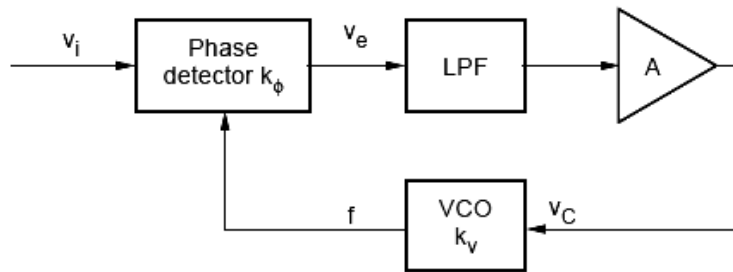

Let us assume that the output voltage of the phase detector is

$$v_e = k_\phi(\theta_e - \pi / 2) \quad (1)$$

where  $\theta_e$  = phase error.

The output voltage of the phase detector is filtered by the low-pass filter to remove the high frequency components. The output of the filter is amplified by a gain A and then applied as the control voltage  $v_c$  to the VCO as given by,

$$v_c = Av_e = k_\phi A(\theta_e - \pi / 2) \quad (2)$$

This control voltage  $v_c$  will result in a shift in the VCO frequency from its center frequency  $f_o$  to a frequency f, given by

$$f = f_o + K_v v_c \quad (3)$$

When the PLL is locked into the input signal frequency  $f_i$ , we have

$$f = f_i = f_o + K_v v_c \quad (4)$$

Substituting value  $v_c$ , we have,

$$f_i - f_o = k_v k_\phi A(\theta_e - \pi / 2)$$

$$\therefore \theta_e - \frac{\pi}{2} = \frac{f_i - f_o}{k_v k_\phi A}$$

$$\therefore \theta_e = \frac{\pi}{2} + \frac{f_i - f_c}{k_v k_\phi A} \quad (5)$$

The maximum output voltage magnitude available from the phase detector occurs for  $\phi = \pi$  and 0 radian and is  $v_e(\max) = \pm k_\phi(\pi/2)$

The corresponding value of the maximum control voltage available to drive the VCO will be

$$v_c(\max) = \pm k_\phi(\pi/2)A \quad (6)$$

Substituting the maximum value of  $v_c$  from equation (6) in equation (4) we have,

$$f = f_i = f_o \pm k_v k_\phi (\pi/2)A = f_o \pm \Delta f_L$$

where  $2\Delta f_L$  will be lock-in frequency range given by,

$$= 2\Delta f_L = k_v k_\phi A \pi$$

$$\therefore \Delta f_L = k_v k_\phi A \pi / 2$$

The lock-in range is symmetrically located with respect to VCO free running frequency  $f_o$ .  
 For PLL 565

We have  $k_v = \frac{8f_o}{V}$

where  $V = +V_{CC} - (V_{CC})$

For PLL 565,

$$k_\phi = \frac{1.4}{\pi}; A = 1.4$$

Substituting these values, we get

$$\Delta f_L = \pm \frac{8f_o}{V} \times \frac{1.4}{\pi} \times \frac{\pi}{2}$$

$$\therefore \Delta f_L = \pm \frac{7.84f_o}{V}$$

## PLL Applications

### Frequency Multiplier/Divider

Following figure shows the block diagram for a frequency multiplier using PLL 565.

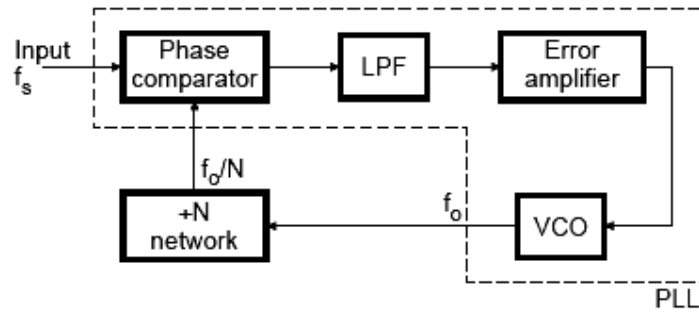

Here, a divide by N network is inserted between the VCO output (pin 4) and the phase comparator input (pin 5). Since the output of the divider is locked to the input frequency the VCO is actually running at a multiple of the input frequency. Therefore, in the locked state, the VCO output frequency  $f_o$  is given by,

$$f_o = Nf_i$$

By selecting proper divider by N network, we can obtain desired multiplication. For example, to obtain output frequency  $f_o = 6 f_i$ , a divide by N should be equal to 6.

### Frequency Synthesizer

The PLL can be used as the basis for frequency synthesizer that can produce a precise series of frequencies that are derived from a stable crystal controlled oscillator. Following figure shows the block diagram of frequency synthesizer.

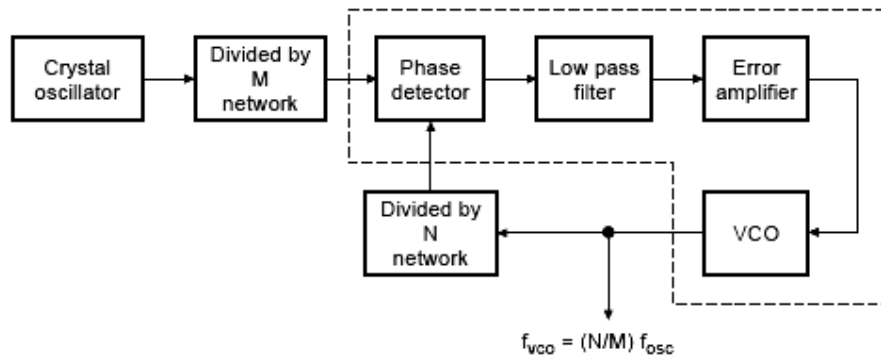

It is similar to frequency multiplier circuit except that divided by M network is added at the input of phase lock loop. The frequency of the crystal-controlled oscillator is divided by an integer factor M by divider network to produce a frequency  $f_{osc}/M$ , where  $f_{osc}$  is the frequency of the crystal controlled oscillator. The VCO frequency  $f_{vco}$  is similarly divided by factor N by divider network to give frequency equal to  $f_{vco}/N$ . When the PLL is locked in on the divided-down oscillator frequency, we will have  $f_{osc}/M = f_{vco}/N$ , so that  $f_{vco} = (N/M) f_{osc}$ .

By adjusting divider counts to desired values large number of frequencies can be produced, all derived from the crystal controlled oscillator.

### FM Demodulator

The PLL can be very easily used as an FM detector or demodulator. Following figure shows the block diagram of FM detector.

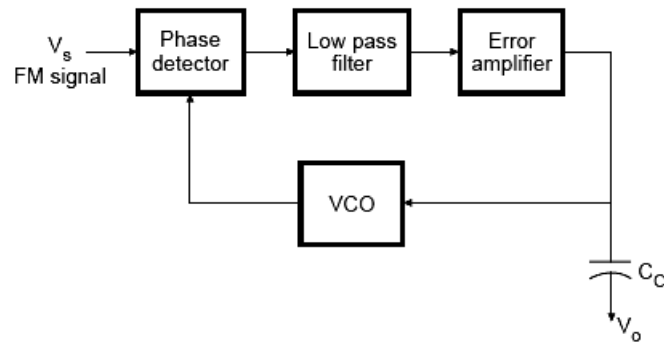

When the PLL is locked in on the FM signal, the VCO frequency follows the instantaneous frequency of the

FM signal, and the error voltage or VCO control voltage is proportional to the deviation of the input frequency from the centre frequency. Therefore, the a-c component of error voltage or control voltage of VCO will represent a true replica of the modulating voltage that is applied to the FM carrier at the transmitter. The faithful reproduction of modulating voltage depends on the linearity between the instantaneous frequency deviation and the control voltage of VCO. It is also important to note that the FM frequency deviation and the modulating frequency should remain in the locking range of PLL to get the faithful replica of the modulating signal. If the product of the modulation frequency  $f_m$  and the frequency deviation exceeds the  $(\Delta f_c)^2$  the VCO will not be able to follow the instantaneous frequency variations of the FM signal.

**Frequency Shift Keying (FSK) Demodulator**

In digital data communication, binary data is transmitted by means of a carrier frequency. It uses two different carrier frequencies for logic 1 and logic 0 states of binary data signal. This type of data transmission is called Frequency Shift Keying (FSK). In this data transmission, on the receiving end, two carrier frequencies are converted into 1 and 0 to get the original binary data. This process is called **FSK demodulation**.

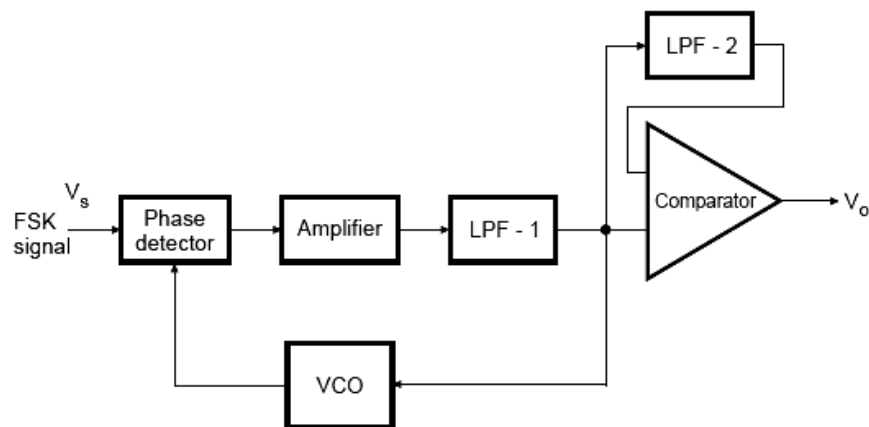

**DESIGN OF ELECTRONIC DEVICES & CIRCUITS****COMMUNICATION CIRCUITS****A FOCUSED APPROACH**

A PLL can be used as a FSK demodulator, as shown in the given figure. It is similar to the PLL demodulator for analog FM signals except for the addition of a comparator to produce a reconstructed digital output signal.

Let us consider that there are two frequencies, one frequency ( $f_1$ ) is represented as "0" and other frequency ( $f_2$ ) is represented as "1". If the PLL remain is locked into the FSK signal at both  $f_1$  and  $f_2$ , the VCO control voltage which is also supplied to the comparator will be given as

$$V_{C1} = (f_1 - f_o) / k_v$$

and

$$V_{C2} = (f_2 - f_o) / k_v$$

where  $k_v$  is the voltage to frequency transfer coefficient of the VCO.

The difference between the two control voltage levels will be  $\Delta V_C = (f_2 - f_1) / k_v$ .

The reference voltage for the comparator is derived from the additional low pass filter and it is adjusted midway between  $V_{C1}$  and  $V_{C2}$ . Therefore, for  $V_{C1}$  and  $V_{C2}$  comparator gives output "0" and "1", respectively.

**AM detection**

A PLL can be used to demodulate AM signals as shown in following figure.

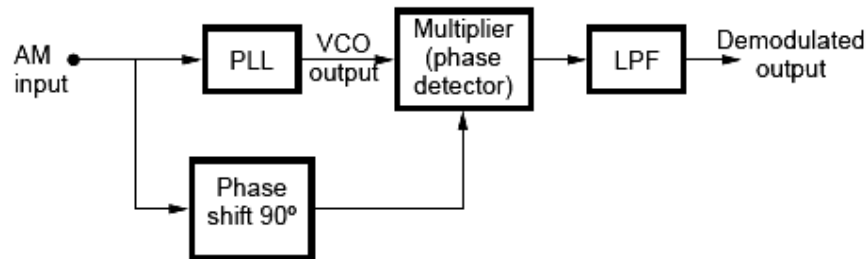

The PLL is locked to the carrier frequency of the incoming AM signal. Once locked the output frequency of VCO is same as the carrier frequency, but it is in unmodulated form. The modulated signal with  $90^\circ$  phase shift and the unmodulated carrier from output of PLL are fed to the multiplier. Since VCO output is always  $90^\circ$  out of phase with the incoming AM signal under the locked condition, both the signals applied to the multiplier are in same phase. Therefore, the output of the multiplier contains both the sum and the difference signals. The low pass filter connected at the output of the multiplier rejects high frequency components gives demodulated output. As PLL follows the input frequencies with high accuracy, a PLL AM detector exhibits a high degree of selectivity and noise immunity which is not possible with conventional peak detector type AM modulators.

**Example (AMIE Summer 2005)**

*The lock range of a certain PLL is specified to be  $\pm 15\%$  of the centre frequency. Determine the minimum and maximum frequencies for which the PLL will maintain lock if  $f_o = 50$  kHz.*

Minimum frequency is given by

$$f_o - \frac{15f_o}{100} = 42.5 \text{ kHz}$$

Maximum frequency is given by

$$f_o + \frac{15f_o}{100} = 50 + 7.5 = 57.5 \text{ kHz}$$

### AMIE (AMIE S15, 7 marks)

The PLL 565 is connected to work as an FM demodulator. Resistor  $R_1$  and capacitor  $C_1$ , which determine the free running frequency  $f_o$  are  $10 \text{ k}\Omega$  and  $220 \text{ pF}$ , respectively. Supply voltage is  $\pm 6\text{V}$ . Determine the free running frequency  $f_o$  and the lock range  $f_L$ .

### Solution

#### Free running frequency

$$f_o = \frac{1.2}{4R_1C_1} \text{ Hz}$$

Given  $R_1 = 10 \text{ k}\Omega$ ;  $C_1 = 220 \text{ pF}$

$$\therefore f_o = \frac{1.2}{4 \times 10 \times 10^3 \times 220 \times 10^{-12}} = 136.36 \text{ kHz}$$

#### Lock range

$$f_L = \frac{8f_o}{V}$$

$$\therefore V = 6 - (-6) = 12 \text{ V}$$

$$\therefore f_L = \frac{8 \times 136.36 \times 10^3}{12} = 90909 \text{ Hz} = 91 \text{ kHz}$$

### VIDEO AMPLIFIER

A video amplifier has to amplify signals over a wideband of frequencies, say upto  $20 \text{ MHz}$ . For faithful reproduction of the picture, the shape and form of the video waveform must be preserved during amplification. The shape of complex waveform depends not only on the frequencies contained in the signal but also upon the relative phases. It is therefore, necessary that :

- All the frequencies must be amplified equally to maintain the same relative amplitudes and

- The relative phases of all the frequency components in the output must be the same as at the input.

From the above discussion we can say that the video amplifier is essentially a wideband amplifier with bandwidth from d.c. to high frequency upto few megahertz. The simplest wideband amplifier is the conventional RC coupled amplifier. We know that, the frequency response of RC coupled amplifier is limited by the coupling capacitor at the low frequency and by the stray shunt capacitance at the high frequency. In a wideband amplifier, such frequency response of RC coupled amplifier is extended using compensation networks. At low frequencies, the problem may be eliminated by direct coupling which is readily possible for one or two limited number of stages. In circuits with capacitor coupling, suitable compensation for low frequency response is possible, the d.c. being restored by d.c. restorer diode clamping circuits. High frequency compensation can be achieved by shunt-series peaking coils in the load circuits. These coils help increase the effective load impedance at high frequencies and increase the gain.

### **A two stage Video amplifier**

Following figure shows MC 1550 used as a video amplifier.

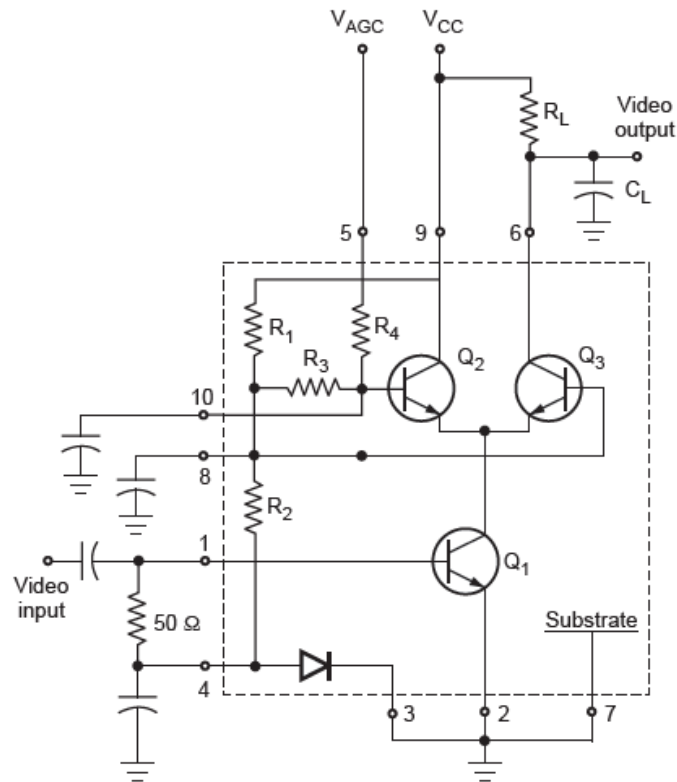

As it uses a cascade amplifier pair, the video amplifier is called cascade video amplifier. The transistor  $Q_1$  is a **common emitter amplifier** and transistor  $Q_3$  is a **common base amplifier** and they together form a **cascade amplifier**.

To properly terminate the co-axial cable carrying the video signal, a  $50\Omega$  resistance is connected between the pins 1 and 4 of MC 1550. Such a small resistance has very negligible effect on the biasing of the transistor. The load resistance  $R_L$  is directly inserted in the collector of the transistor  $Q_3$ .

The following figure shows the small signal approximate equivalent circuit for video amplifier.

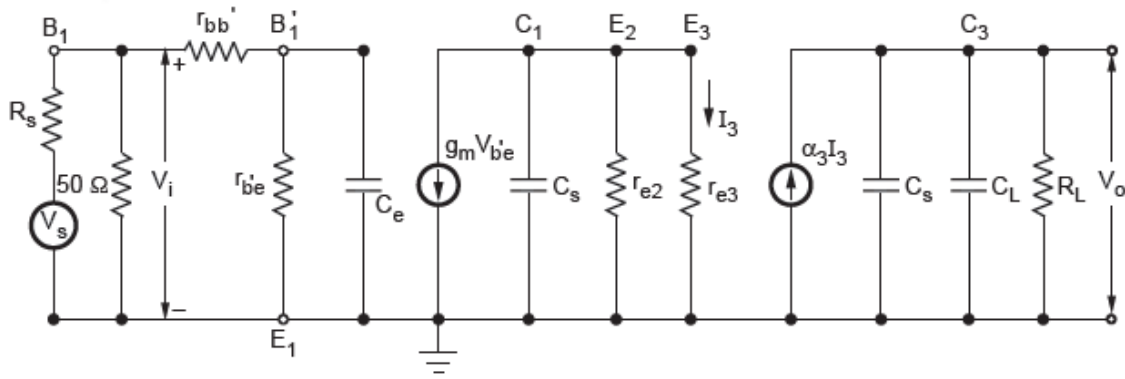

Both  $Q_2$  and  $Q_3$  are operating in their active region, therefore the collector of  $Q_1$  sees the very small input resistance ( $r_{e2} \parallel r_{e3}$ ) of two common-base stages in parallel.

The voltage gain for this video amplifier is given as

$$\frac{V_o}{V_i} = -\frac{\alpha_3 g_m}{r_{e3} r_{bb'}} \cdot \frac{1}{\left(\frac{1}{r_{bb'}} + \frac{1}{r_{be}} + sC_e\right) \left(\frac{1}{r_{e2}} + \frac{1}{r_{e3}} + sC_s\right) \left[\frac{1}{R_L} + s(C_s + C_L)\right]}$$



## **ASSIGNMENT**

**Q.1. (AMIE S17, 10 marks):** What is modulation? What is the purpose of modulation in electrical communication?

**Q.2. (AMIE W18, 5 marks):** Explain how a comparator can be used as a pulse width modulator. Draw the modulating waveform and the corresponding output waveform.

**Q.3. (AMIE W17, 8 marks):** Explain the operation of a square band demodulator and derive the mathematical expression recovering the original unmodulated signal.

**Q.4. (AMIE W17, 5 marks):** What is synchronous detection? How is synchronous detection affected by phase error and frequency error? How can you obtain coherent carrier of receiver for the circuit?

**Q.5. (AMIE S17, 12 marks):** Explain DSB-SC (double sideband suppressed carrier) modulation. Obtain the expression or single tone DSB-SC modulated wave and find its spectrum. Plot it in time-domain and frequency domain.

**Q.6. (AMIE S15, 7 marks):** Show that, in balance AM modulator, the carrier is suppressed.

**Q.7. (AMIE W18, 5 marks):** An analog multiplier is used to generate an AM signal. Show that the carrier frequency does not explicitly appear in the output of the multiplier.

**Q.8. (AMIE S15, 4 marks):** State the relative merits of AM, DSB-SC and SSB-SC systems.

**Q.9. (AMIE W16, 6 marks):** Discuss with a neat circuit, the working of a Foster Seeley discriminator.

**Q.10. (AMIE W19, 5 marks):** Explain how a square law electronic device can be used to provide an AM signal.

**Q.11. (AMIE W15, 4 marks):** Explain how an AM signal can be demodulated using a square law detector.

**Q.12. (AMIE S15, 3 marks):** Why is coherent or synchronous demodulation of AM rarely used in practice?

**Q.13. (AMIE W18, 3 marks):** Distinguish between narrow band FM and wide-band FM.

**Q.14. (AMIE S16, 7 marks):** Draw a simplified schematic of balanced modulator and demodulator. Find the limitations of envelope detection in this case.

**Q.15. (AMIE S15, W15, 6 marks):** Draw and explain the block diagram of a superheterodyne receiver.

**Q.16. (AMIE S15, 4 marks):** Why is the intermediate frequency (IF) selected as 455 kHz?

**Q.17. (AMIE S15, 3 marks):** With reference to FM, what is "capture effect"?

**Q.18. (AMIE W15, 16, 7 marks):** What is a PLL? How does it work? Discuss its applications.

**Q.19. (AMIE S17, 8 marks):** With the help of a block diagram and necessary equations, explain the Phase Locked Loop demodulator for a FM wave.

**Q.20. (AMIE W19, 7 marks):** Show that the lock-in range of a PLL is given by

$$\Delta f_L = \pm 7.8 f_o / V$$

**Q.21. (AMIE W19, 3 marks):** What is the major difference between analog and digital PLLs?

**Q.22. (AMIE S16, 18, 5 marks):** Explain a frequency multiplier circuit.

**Q.23. (AMIE S19, 10 marks):** Explain how frequency multiplication affects frequency modulation.

**Q.24. (AMIE S19, 7 marks):** Design a frequency synthesizer using PLL.

**Q.25. (AMIE W15, S19, 8 marks):** Draw the circuit diagram of a typical two stage video amplifier and explain how it works.

**DESIGN OF ELECTRONIC DEVICES & CIRCUITS****COMMUNICATION CIRCUITS**

**Q.26. (AMIE W16, 8 marks):** Explain M-ary FSK system with the help of transmitters and receivers. Determine the bandwidth required for M-ary FSK system.

**Q.27. (AMIE S19, 10 marks):** Sketch constellation diagram and block diagram of FSK with its advantages and disadvantages.

**Q.28. (AMIE S18, 4 marks):** Using a neat block diagram, explain how a PLL can be used as a FSK demodulator.

**NUMERICALS**

**Q.29. (AMIE S15, 6 marks):** Determine the percentage of the total power carried by the sidebands of an AM wave for tone modulation when the modulation index  $\mu = 0.5$ .

Answer: 11.1%

**Q.30. (AMIE W16, 6 marks):** The percent modulation of an AM wave changes from 40% to 60%. Originally the power content at the carrier frequency was 900 W. Determine the power content at the carrier frequency and within each of the sidebands after the present modulation has risen to 60%.

Answer: 81 W

*(For online support such as eBooks, video lectures, audio lectures, unsolved papers, online objective questions, test series and course updates, visit [www.amiestudycircle.com](http://www.amiestudycircle.com))*